

WATER TREATMENT & PURIFICATION

POINT-OF-USE (POU) & POINT-OF-ENTRY (POE)

- ◆ Filtration
- ◆ Ultraviolet (UV)
- ◆ Ozonation
- ◆ Reverse Osmosis
- ◆ Water Softeners
- ◆ Distillation
- ◆ Water Purifiers

DRINKING WATER SYSTEM CHEMICALS

- ◆ Corrosion & Scale Inhibitors
- ◆ Coagulants & Flocculants
- ◆ Disinfection & Oxidation Chemicals
- ◆ pH Adjustment, Softening, Precipitation & Sequestering Chemicals
- ◆ Well Drilling Aids

DRINKING WATER SYSTEM COMPONENTS / MATERIALS

- ◆ Protective Barrier Materials (cements, coatings, paint)
- ◆ Joining & Sealing Materials (gaskets, lubricants, adhesives)
- ◆ Mechanical Devices (water meters, valves, filters)
- ◆ Pipes & Related Products (pipe, hose, fittings)
- ◆ Plumbing Devices (faucets, drinking fountains)

PEST MANAGEMENT

- ◆ Algicides
- ◆ Antifouling Agents
- ◆ Pool Chemicals
- ◆ Molluscicides
- ◆ Piscicides

- ⇒ NSF/ANSI Water Treatment Standards
- ⇒ CSA B483.1 Drinking Water Treatment Systems
- ⇒ PMRA Registration Package Preparation
- ⇒ Test Protocol Development
- ⇒ Technology Development
- ⇒ Labels / Manuals / Packaging
- ⇒ Material / Component / Product Traceability

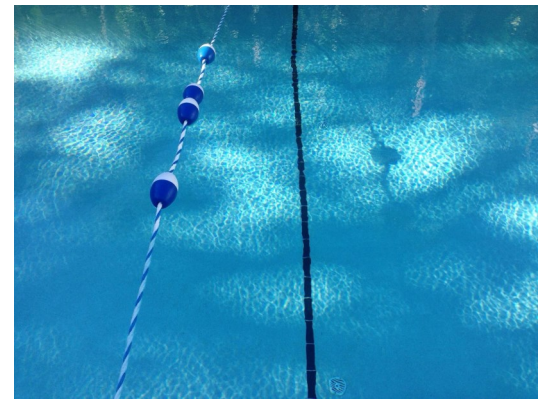
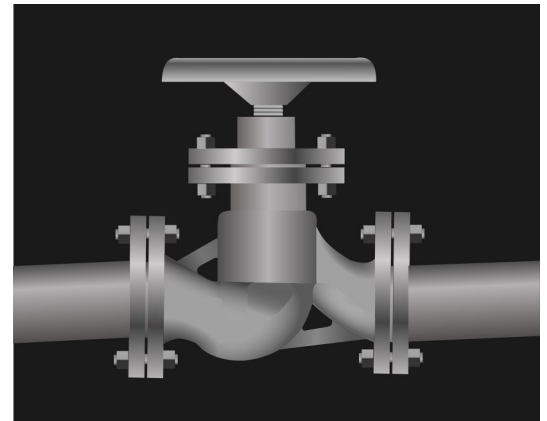

“This is a very complex multi-domain process requiring knowledge of chemistry, materials and the regulatory process. They handled it beautifully.”